

# MANUAL

## D2510

### Miniature SMART Pressure Transmitter with LHP Communication



- Only three basic ranges cover pressures from 60 kPa to 4 MPa.
- Programmable current output 4 to 20 mA with LHP communication.
- Possibility of easy remote configuration, zero setting and reversal.
- Accuracy 0.5 or 0.25 %, miniature dimensions.
- Stainless steel diaphragm.
- Remote reconfiguration by LHPConf configurator or by the LHPWinConf software and standard HART modem.

Архангельск (8182)63-90-72  
Астана +7(7172)727-132  
Белгород (4722)40-23-64  
Брянск (4832)59-03-52  
Владивосток (423)249-28-31  
Волгоград (844)278-03-48  
Вологда (8172)26-41-59  
Воронеж (473)204-51-73  
Екатеринбург (343)384-55-89  
Иваново (4932)77-34-06  
Ижевск (3412)26-03-58  
Казань (843)206-01-48

Калининград (4012)72-03-81  
Калуга (4842)92-23-67  
Кемерово (3842)65-04-62  
Киров (8332)68-02-04  
Краснодар (861)203-40-90  
Красноярск (391)204-63-61  
Курск (4712)77-13-04  
Липецк (4742)52-20-81  
Магнитогорск (3519)55-03-13  
Москва (495)268-04-70  
Мурманск (8152)59-64-93  
Набережные Челны (8552)20-53-41

Нижний Новгород (831)429-08-12  
Новокузнецк (3843)20-46-81  
Новосибирск (383)227-86-73  
Орел (4862)44-53-42  
Оренбург (3532)37-68-04  
Пенза (8412)22-31-16  
Пермь (342)205-81-47  
Ростов-на-Дону (863)308-18-15  
Рязань (4912)46-61-64  
Самара (846)206-03-16  
Санкт-Петербург (812)309-46-40  
Саратов (845)249-38-78

Смоленск (4812)29-41-54  
Сочи (862)225-72-31  
Ставрополь (8652)20-65-13  
Тверь (4822)63-31-35  
Томск (3822)98-41-53  
Тула (4872)74-02-29  
Тюмень (3452)66-21-18  
Ульяновск (8422)24-23-59  
Уфа (347)229-48-12  
Челябинск (351)202-03-61  
Череповец (8202)49-02-64  
Ярославль (4852)69-52-93

**Contents**

- 1. General instructions and information**
  - 1.1 Symbols used ..... 3
  - 1.2 Safety warnings and cautions ..... 3
  - 1.3 Scope of delivery ..... 3
  - 1.4 Description of the delivery and packing ..... 3
  - 1.5 Storage ..... 3
  - 1.6 Installation, operation and maintenance ..... 3
  - 1.7 Spare parts ..... 3
  - 1.8 Repairs ..... 3
  - 1.9 Warranty..... 3
- 2. End of service and disposal**
  - 2.1 End of service ..... 3
  - 2.2 Disposal ..... 3
- 3. Product description**
  - 3.1 Application ..... 4
  - 3.2 Description..... 4
  - 3.3 Block Diagram..... 5
  - 3.4 Dimensional drawings..... 5
- 4. Installation, operation and maintenance**
  - 4.1 Installation and commissioning ..... 6
  - 4.2 Operation and maintenance..... 7
  - 4.3 Error handling ..... 7
- 5. Product specifications**
  - 5.1 Technical specifications..... 8
  - 5.2 Supplementary parameters ..... 8
- 6. Tests, certificates and standards**
  - 6.1 Standards ..... 8
  - 6.2 Marking and type tag information ..... 8
- 7. Ordering information**
  - 7.1 Ordering table ..... 9
  - Contacts..... 10

## 1. General instructions and information

### 1.1 Symbols used



Symbol of warning; for safe use it is necessary to proceed according to the instructions



Symbol CE certifies compliance of the product with the respective government directives



Symbol of "Output"



Symbol of "Supply"



This product does not belong to public waste and it is subjected to separate collection

### 1.2 Safety warnings and cautions



The equipment shall be supplied from a safe voltage source that meets all requirements of the standard EN 61010-1 and must be installed in compliance with national requirements and standards providing safety.

The equipment may only be installed by a qualified personnel who are familiar with national and international laws, directives, standards and with the instructions manual. The instrument may not be used for other purposes than as specified in this instruction manual.

For elimination of a risk of injury from electric shock or fire the maximum operational parameters of the instrument may not be exceeded, particularly range of operating temperature because of exposure to heat from connected or surrounding technological equipment must not be exceeded!

The equipment should be installed in suitable environment without any direct sunlight, occurrence of dust, high temperatures, mechanical vibrations and shocks and protected against rain and excessive moisture.

### 1.3 Scope of delivery

With the product is delivered:

- Manual for installation, operation and maintenance
- Certificate of calibration (only with calibrated sensors)

### 1.4 Description of the delivery and packing

The product is packaged in a protective cover and provided with an identification label with a mark of the output control.

Packaged products are transported in covered vehicles.

### 1.5 Storage

Store the instrument in dry rooms at temperatures from -40 to +80 °C without condensation of water vapours.

## 1.6 Installation, operation and maintenance

During installation, commissioning, operation and maintenance follow the instructions in chapter 4.

### 1.7 Spare parts

Any of the compact parts of the product can be also ordered as a spare part if there is not required special procedures or technological operations for the exchange.

### 1.8 Repairs

Products are repaired by the manufacturer. The products for repair should be sent together with description of the fault or defect in a packing that guarantees damping of shocks and vibrations and protects against damage during transport.

### 1.9 Warranty



Products are covered by a warranty for a period of 24 months from the delivery date on the delivery note. The manufacturer guarantees technical and operational parameters of the products within scope of the applicable documentation. Warranty period is specified with individual items and begins from the day of takeover of the goods by the purchaser or delivery to the carrier. Any claims concerning to defects of the goods together can be filed with the seller within the warranty period and the claimed product shall be presented. The claiming party shall give identification of the product, number of the delivery note and description of the fault or defect. The seller is not responsible for any defects caused by improper storage, incorrect connection, damages caused by external effects, in particular by effects of factors with excessive values, unqualified installation, improper operation or common wearing.

## 2. End of service and disposal

### 2.1 End of service



Dismounting and disposal of the device is possible after disconnecting of power supply.

### 2.2 Disposal



When disposing the packing and destroyed or irreparably damaged product proceed according to the local regulations.

### 3. Product description

## D2510

### Miniature SMART Pressure Transmitter with LHP Communication

- Only three basic ranges cover pressures from 60 kPa to 4 MPa.
- Programmable current output 4 to 20 mA with LHP communication.
- Possibility of easy remote configuration, zero setting and reversal.
- Accuracy 0.5 or 0.25 %, miniature dimensions.
- Stainless steel diaphragm.
- Remote reconfiguration by LHPConf configurator or by the LHPWinConf software and standard HART modem..



#### 3.1 Application

The D2510 pressure transmitter is designed for multipurpose use in all industry fields. It converts gas or liquid pressures into the electric current or voltage signal. The output is the 4 to 20 mA current loop signal with possibility of zero setting, range resetting and output reversal via LHP communication along the output line. Reversed range is set by entering the higher pressure value for the range start and the lower pressure value for the range end. The model with the voltage output converts pressure into the 1 to 5 V voltage signal.

Thanks to adjustable damping it enables suppression of undesirable quick variations and oscillations of the output signal. Measured pressure medium should be compatible with the 1.4571 and 1.4435 stainless steels and with the used seal (see ordering table).

#### 3.2 Description

Output voltage signal of the pressure sensor is transferred to the digital signal and further processed by the microcomputer. These values are recalculated to the pressure value through the production calibration constants and the user characterization constants. The output current is sent out via the D/A converter and the output circuits in accordance with the computed pressure value and the set range.

Output of the transmitter is analogue signal of the current loop 4 to 20 mA or the 1 to 5 V voltage signal. The output can be used even for testing the current loop and the associated apparatus.

Transmitter adjustment requires the hand-held LHPConf (HARTConf) configurator, or the PC with the LHPWinConf program and the HARTMod (MH-02) modem, or with the equivalent communication interface. The transmitter communicates via its own LHP communication protocol that is partly compatible with the HART protocol with which it shares the same connection. Communication serves mainly for converter configuration and it is not intended for communication distance over 20 m. By means of the standard HART communicator it is possible to display basic setting parameters and to adjust the range by application of the input pressure.

### 3.3 Block Diagram

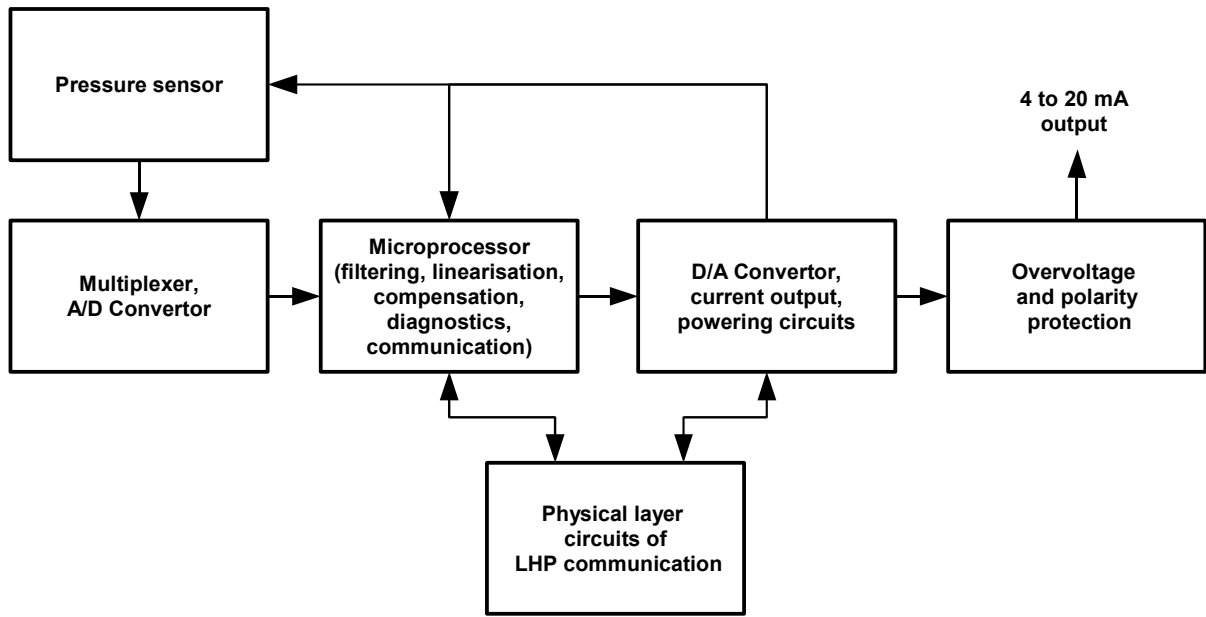

### 3.4 Dimensional drawings

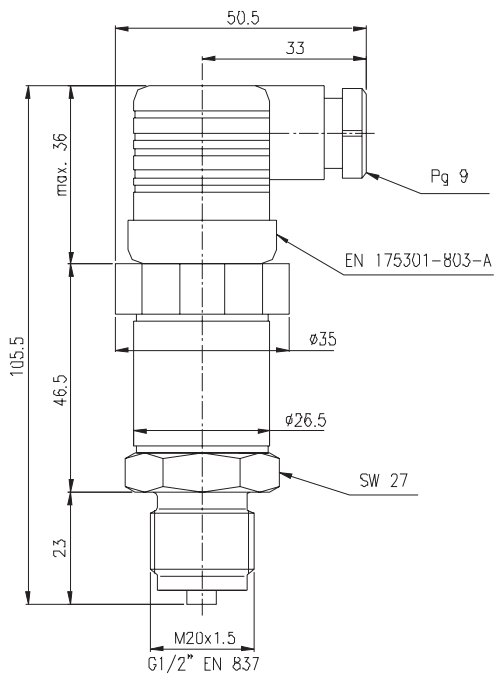

## 4. Installation, operation and maintenance

### 4.1 Installation and commissioning

#### 4.1.1 General information

- Do not use any force when installing the device.
- Keep in mind that this is an electronic device.
- Handle this high-sensitive electronic precision measuring device with care to prevent damage of the device.
- To avoid damaging the diaphragm, remove protective cap (if delivered) directly before starting assembly.
- The protective cap has to be stored! Place the protective cap on the pressure port again immediately after disassembling.
- Handle the unprotected diaphragm very carefully - it is very sensitive and may be easily damaged.
- After installation and proper connection, check the tightness of pressure connections.
- Device is put into operation by switching on the power supply.

#### 4.1.2 Special information

- Take note that no assembly stress occurs at the pressure connection, since this may cause a shifting of the characteristic curve. This is especially important for very small pressure ranges.
- If there is any danger of damage by lightning or overpressure when the device is installed outdoor, we suggest putting a sufficiently dimensioned overpressure or overvoltage protection between the supply or switch cabinet and the device.
- For outdoor and damp areas installations follow these instructions:
  - If possible, choose such assembly position and location, that the sensor is protected against rain and that the condensation water can freely flow-off on the surface and doesn't stay in the holes for screw, seal grooves or in vent opening (small hole next to the electrical connection).
  - Avoid permanent fluid at sealing surfaces!
  - Install the device in such way that it is protected from direct solar irradiation. Adverse conditions can cause that the permissible operating temperature can be overstepped and the operability of the device can be affected or damaged. In addition, if the internal pressure increases due to solar irradiation, temporary measurement errors may be caused.
- For devices for gauge pressure with gauge reference (small hole next to the electrical connection), take note to:
  - Check and verify if the IP protection is sufficient for the intended environment.
  - Install the device in such a way, that the gauge reference necessary for the correct measurement of gauge pressure (small hole next to the electrical connection) is protected from dirt and moisture. If the gauge reference is clogged by liquid or dirt, the device will not function properly and will not measure precisely. Furthermore, getting moisture inside the sensor can lead to permanent damage of the device.

#### 4.1.3 Installation steps

Follow detailed instructions according to specific pressure connection below.

#### Installation steps for EN 837

- Use a suitable seal, corresponding to the medium and the pressure input (e. g. a cooper gasket). Sealing is not part of the supply.
- Ensure that the sealing surface of the taking part is perfectly smooth and clean.
- Screw the device into the corresponding thread by hand.
- Tighten it with a wrench (for G1/2": approx. 50 Nm).

#### 4.1.4 Electrical connection

Connector EN 175301-803-A (IP 65, in the short-term, not suitable for outdoor installation without additional rain-proof protection).

When measuring small relative pressures, it is necessary to use the electric cable with a through capillary for supply of ambient atmospheric pressure to the measuring membrane in order to provide correct measurement results.

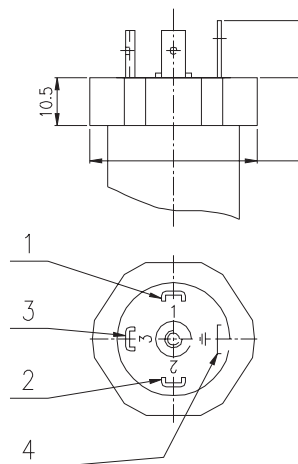

Output 4 to 20 mA, power supply from the current loop:

- 1 - PLUS output and power supply
- 2 - MINUS output and power supply, minus TEST (mA)
- 3 - plus TEST (mA)
- 4 - case, shield

The TEST terminals are designed for measuring the output current by the ammeter with internal resistance  $R_i < 15 \text{ ohm}$ .

The modem or the configurator are to be connected to the terminals 1 and 2. Loop impedance should be 200 Ohm at least to ensure communication.

Output 1 to 5 V:

- 1 - PLUS power supply
- 2 - MINUS output and power supply
- 3 - plus OUTPUT (output internal resistance 250 Ohm)
- 4 - case, shield

The modem or the configurator are to be connected to the terminals 1 and 3, or 2 and 3.

**4.1.5 Steps for changing the range**

**a) By the LHPWinConf<sup>1)</sup> software and HARTMod modem (or the HARTConf configurator functioning as the modem)**

1. Connect power supply from the 24 VDC source to the transmitter terminals 1 and 2 through the 250 Ohm resistance. Connect the modem output to the terminals 1 and 2 and connect the modem serial communication cable to the free RS232 port of the PC, or to the USB port, if the HARTConf configurator functioning as the modem is used instead of the HARTMod modem.
2. Launch the LHPWinConf program that will find the communication modem without any assistance. If this is not the case, you can direct the program to the particular port by clicking the HART Driver icon in the right bottom corner of the screen. Thus the HART Driver panel is displayed and it is possible to set the appropriate port (COM1 up to COM10).
3. Follow the program steps. You can perform for example zero setting, range resetting using a keyboard or calibration of the range start and end by means of the precise pressure source. Complete 5-point user calibration is available as well.
4. Using the program it is also possible to set other output parameters, such as error current signal, step response time, units and text annotations. In addition you can test the current output etc. Setting can be stored and printed out.

**b) By the LHPConf<sup>2)</sup> or HARTConf<sup>2)</sup> configurators**

1. Connect the configurator output to the transmitter terminals 1 and 2.
2. Switch on the configurator and if power supply of the transmitter from the configurator is not set, switch it on (Options/Power Supply/Internal). In menu "Configuration/Lower RV" and "Configuration/Upper RV" perform necessary range settings. In case you use the precise pressure source set pressure and select "Apply Value". If you want to make re-configuration by entering the value, select "Enter Value", and enter and confirm change of the value.
3. By means of the configurator you can set other output parameters as well, such as error current signal, step response time, units and text annotations. In addition you can test the current output etc.

<sup>1)</sup> Revision 2.0.0 at least

<sup>2)</sup> Firmware revision 1.1.0 at least

**4.2 Operation and maintenance**

The operator can read the settings and measured values of correctly installed device by communicator. Changing of the device settings may be done only if a sudden change of the output current could not cause failure of the process equipment (possible controller switch to manual control)!

The device is maintenance free. In case of the contamination clean the pressure connection regularly and clean it regardless to medium and contamination. Do not use aggressive cleaning solvents. Do not use pressurized water.

**4.3 Error handling**

Malfunction	Possible cause	Error detection / corrective
no output signal	faulty connection	inspect the connection
	line break	inspect all line connections necessary to supply the device (including the connector plugs)
	defective amperemeter (signal input)	inspect the amperemeter (fuse) or the analogue input of the PLC
analogue output signal too low	load resistance too high	verify the value of the load resistance
	supply voltage too low	verify the output voltage of the power supply
	defective energy supply	inspect the power supply and the applied supply voltage at the device
small shift of output signal	diaphragm is highly contaminated	careful cleaning with non-aggressive cleaning solution and a soft brush or sponge; incorrect cleaning can cause irreparable damages on diaphragm or seals
	diaphragm is calcified or coated with deposit	if possible, it is recommended to send the device to JSP, s.r.o. for decalcification or cleaning
large shift of output signal	diaphragm is damaged (caused by overpressure or manually)	check the diaphragm; if it is damaged, please send the device to JSP, s.r.o. for repair
wrong or no output signal	manually, thermally or chemically damaged cable	check the cable; a possible consequence of a damaged cable is pitting corrosion on the stainless steel housing; if you determine this please return the device to JSP, s.r.o. for repair



## 5. Product specifications

### 5.1 Technical specifications

#### Supply voltage:

9 to 35 VDC for 4 to 20 mA current output  
15 to 35 VDC for 1 to 5 voltage output  
(Internally protected against polarity inversion)

#### Power consumption:

max 0.8 W

#### Range of ambient temperature:

-20 to +85 °C

#### Humidity:

0 to 100 % r. h. with condensation

#### Working position:

arbitrary (for lower pressure zero calibration after installation may be needed)

#### Connection of wires:

screw terminals for cross section 0.5 to 1.5 mm<sup>2</sup>

#### Protection:

IP 65

#### Dimensions:

see dimensional drawing

#### Weight:

about 140 g

#### Materials:

housing - stainless steel 1.4301, connector - PA  
Media wetted materials:  
pressure port - stainless steel 1.4571  
diaphragm - stainless steel 1.4435  
seals – see ordering table

#### Reference conditions:

Temperature 23 ± 5 °C  
Vertical working position with pressure port down  
Zero based range with span between 20 % and 100 %  
of max span  
Supply voltage 24 VDC  
Load of 250 Ohm  
Damping of 0.1 s

#### 5.1.1 Input

##### Input pressure ranges:

see ordering table

##### Design of pressure port:

see ordering table and dimensional drawings

##### Overpressure:

3.5 times of max span for G160 to G216 and A160 ranges  
2.5 times of max span for G240 ranges

#### 5.1.2 Output

##### Output signal:

4 to 20 mA or 20 to 4 mA current signal  
optional 1 to 5 V voltage signal with output  
resistance of 250 Ohm

##### Characteristics:

Linear with pressure with possibility of custom linearization

##### Total accuracy:

≤ ± 0.5 % of span (0.25 % for code P03)  
(Valid for reference conditions. For span between  
±10 % and ± 20 % of max span is total error  
≤ ± 0.1 % x max span / range span and for ranges with  
zero offset the error is multiplied by  
suppression coefficient = max. range span / range span.)

##### Nonlinearity:

≤ ± 0.25 % of range

##### Hysteresis:

≤ ± 0.25 % of range

##### Adjustability of span:

from ± 10 % to ±100 % of max span  
(negative values are valid for reversed range)

##### Adjustability of start:

from 0 % to 100 % of max span

##### Damping:

0 to 60 s

##### Step response time (90 %):

0.6 s for damping of 0.0 s  
0.9 s for damping of 0.1 s  
60 s for damping of 60 s

##### Sampling rate:

about 4 measurement per second

##### Load resistance:

$R_L [\text{Ohm}] \leq (U_N [\text{V}] - 9) / 0.022$

##### Dielectric strength:

500 VAC (output against the metal housing)

##### Isolation resistance:

min. 100 MOhm

## 5.2 Supplementary parameters

##### Lifetime:

≥ 100 x 10<sup>6</sup> pressure cycles

##### Output current limitation:

Signal 3.8 to 20.5 mA acc. to NAMUR NE43

##### Indication of sensor or transmitter error:

Optionally by > 21 mA or < 3.6 mA current acc. to  
NAMUR NE43

##### Supply voltage effect:

≤ ± 0.01 % of span per 1 V

##### Influence of ambient temperature:

Zero accuracy < ± 0.6 % of max span for temperature from  
-20 to 85 °C  
Span accuracy < ± 0.8 % of span for temperature from  
-20 to 85 °C

##### Warm-up time:

5 s

##### Long-term stability:

≤ ± 0.2 % of max span per year

## 6. Tests, certificates and standards

### 6.1 Standards

Accuracy acc. to EN 60770-1:2000

EMC acc. to EN 61326



# Miniature SMART Pressure Transmitter D2510 with LHP Communication

## 7. Ordering information

### 7.1 Ordering table

Type	Description
• D2510	Smart miniature pressure transmitter with LHP communication
Code	Basic range
• G160	Gauge pressure, setting from 0 ÷ 60 kPa to 0 ÷ 600 kPa
• G216	Gauge pressure, setting from 0 ÷ 160 kPa to 0 ÷ 1.6 MPa
• G240	Gauge pressure, setting from 0 ÷ 400 kPa to 0 ÷ 4 MPa
◦ A160	Absolute pressure, setting from 0 ÷ 60 kPa to 0 ÷ 600 kPa
Code	Pressure connection
◦ GE2	G1/2" EN 837-1/-3 (manometric)
• ME2	M20x1.5 EN 837-1/-3 (manometric)
Code	Sealing
• 1	Viton (FKM)
Code	Accuracy
• P05	0.5 % (standard)
◦ P03	0.25 %
Code	Calibration
◦ KTL	Certificate of calibration
Code	Output signal
• CR	4 to 20 mA, EN 175301-803-A connector (DIN 43650) (IP 65)
◦ VR	1 to 5 V, EN 175301-803-A connector (DIN 43650) (IP 65)
Code	Software setting of range
• NR	Without setting, range set to maximum limits of base range and DP (0.1 s) ECH
• RL	Setting lower value (fill in value and units)
• RH	Setting upper value (fill in value and units)
Code	Software setting of damping
• DP	Output damping, fill value in seconds, standard DP (0.1 s)
Code	Software setting of alarm errors
• ECL	Error current below 3.6 mA
• ECH	Error current above 21 mA
Code	Optional accessories
• BZS	Label customer indications with description according to order
• LHPWinCom	Set of configuration program LHPWinConf for PC (supported by WINXP/Vista/7/8) and modem HARTMod
• LHPConf	Field configurator for transmitters with LHP communication, function of transmitter supply, without charging
• HARTConf	HART-USB modem and field communicator for LHP and HART transmitters, function of transmitter supply, supplied from USB or built-in accumulator
• HARTMod	Miniature HART modem with galvanic isolation
• LHPWinConf	Configuration software LHPWinConf (CZ+EN) for PC (WINXP/Vista/7/8)
• USB-RS232	Communication Interface for USB port of the PC
• TTRN 1	Pressure shock absorber, M20x1.5 EN 837-1/-3 / M20x1.5 (DIN 3852, EN 837-1/-3), stainless steel
• TTRN 2	Pressure shock absorber, M20x1.5 EN 837-1/-3 / G1/2" (DIN 3852, EN 837-1/-3), stainless steel
◦ TTRN 4	Pressure shock absorber, G1/2" EN 837-1/-3 / G1/2" (DIN 3852, EN 837-1/-3), stainless steel
◦ TTRN 5	Pressure shock absorber, G1/2" EN 837-1/-3 / M20x1.5 (DIN 3852, EN 837-1/-3), stainless steel
• VZOG	Testing valve of carbon steel with G1/2" nut (for pressure connector code GE2), (1 110 491, see data sheet No. 0082)
• VZNG	Testing valve of stainless steel with G1/2" nut (for pressure connector code GE2), (1 110 492, see data sheet No. 0082)
◦ VZOM	Testing valve of carbon steel with M20x1.5 nut (for pressure connector code ME2), (1 110 415, see data sheet No. 0082)
◦ VZNM	Testing valve of stainless steel with M20x1.5 nut (for pressure connector code ME2), (1 110 416, see data sheet No. 0082)
• 1 780 067	Condensation loop, U-form, type B, PN 250, Tmax 300 °C, connection M20x1.5, carbon steel 1.0570 (see data sheet No. 0082)
• 1 780 059	Condensation loop, U-form, type B, PN 250, Tmax 300 °C, connection M20x1.5, stainless steel 1.4541 (see data sheet No. 0082)
• 1 780 069	Coiled condensation loop, type D, PN 250, Tmax 300 °C, connection M20x1.5, carbon steel 1.0570 (see data sheet No. 0082)
• 1 780 061	Coiled condensation loop, type D, PN 250, Tmax 300 °C, connection M20x1.5, stainless steel 1.4541 (see data sheet No. 0082)
• NP 1	Adapter with connection M20x1.5, PN 630, Tmax 400 °C, material of adapter 1.0570 / connection 1.4301 (see data sheet No. 0082)
• NP 4	Adapter with connection M20x1.5, PN 630, Tmax 400 °C, material of adapter 1.4301 / connection 1.4301 (see data sheet No. 0082)
• DMS	Bracket for pressure sensor with pipe union, material 1.4541, PN 400, for mounting on the wall (see data sheet No. 2280)
<b>Example of order: D2510 G160 ME2 1 P05 KTL CR NR</b>	
<b>D2510 A160 ME2 1 P05 KTL CR RL (100 kPa) RH (250 kPa) ECH</b>	

**2 years warranty**

• ... Ex stock version

◦ ... Marked version can be dispatched up to 10 working days

Архангельск (8182)63-90-72  
Астана +7(7172)727-132  
Белгород (4722)40-23-64  
Брянск (4832)59-03-52  
Владивосток (423)249-28-31  
Волгоград (844)278-03-48  
Вологда (8172)26-41-59  
Воронеж (473)204-51-73  
Екатеринбург (343)384-55-89  
Иваново (4932)77-34-06  
Ижевск (3412)26-03-58  
Казань (843)206-01-48

Калининград (4012)72-03-81  
Калуга (4842)92-23-67  
Кемерово (3842)65-04-62  
Киров (8332)68-02-04  
Краснодар (861)203-40-90  
Красноярск (391)204-63-61  
Курск (4712)77-13-04  
Липецк (4742)52-20-81  
Магнитогорск (3519)55-03-13  
Москва (495)268-04-70  
Мурманск (8152)59-64-93  
Набережные Челны (8552)20-53-41

Нижний Новгород (831)429-08-12  
Новокузнецк (3843)20-46-81  
Новосибирск (383)227-86-73  
Орел (4862)44-53-42  
Оренбург (3532)37-68-04  
Пенза (8412)22-31-16  
Пермь (342)205-81-47  
Ростов-на-Дону (863)308-18-15  
Рязань (4912)46-61-64  
Самара (846)206-03-16  
Санкт-Петербург (812)309-46-40  
Саратов (845)249-38-78

Смоленск (4812)29-41-54  
Сочи (862)225-72-31  
Ставрополь (8652)20-65-13  
Тверь (4822)63-31-35  
Томск (3822)98-41-53  
Тула (4872)74-02-29  
Тюмень (3452)66-21-18  
Ульяновск (8422)24-23-59  
Уфа (347)229-48-12  
Челябинск (351)202-03-61  
Череповец (8202)49-02-64  
Ярославль (4852)69-52-93